



Connection offline

**Workshop campaign 28E9**Transaction No.: **2019112/6**

Replacing ignition coils

Release date: 16-Sep-2010

**Notes****Repair instructions****Technical background**

It is possible that an ignition coil can fail to function, in which case the emissions warning lamp will light up, as designed. In some cases, the customer may also notice that the vehicle pulls unevenly.

**Remedy**

The ignition coils must be checked on all affected vehicles and replaced if necessary.

**Customer notification****Workshop campaign**

Please notify customers who have taken delivery of one of the affected vehicles when the vehicles are in the workshop.

Please ensure that all affected vehicles are checked and repaired during the next service visit. Make a note of the required campaign on the workshop order before signature by the customer.

If it is omitted to perform the work required for the campaign during a workshop visit, notify the customer about the campaign immediately (registered mail with advice of receipt).

You should also pass on this information to your new and used car sales department so that the vehicles affected are checked and, if necessary, repaired immediately.

**Warranty accounting instructions**

Damage number:	28E9 066 002
Repair code:	Damage cause: repair operation / replacement part (AP/ET) (ignition coil)
Type of claim:	7 10 = Campaign implemented on registered vehicle 7 90 = Campaign implemented on vehicle that has not yet been registered
Note:	<b>All criteria for which work has been performed must be listed in the window "criterion ID" when making out the claim.</b>
Criterion:	See "vehicle-specific notes" (in Service Online or ELSA) <b>ZA</b> = 3.6 ltr. FSI engine <b>ZB</b> = 2.8 ltr. FSI engine <b>Z0</b> = 5.2 ltr. FSI engine <b>Z1</b> = 1.8 ltr. turbo MPI engine / 1.8 ltr. turbo FSI engine

	<p><b>Z2</b> = 2.0 ltr. FSI engine/2.0 ltr. turbo FSI engine/ 2.0 ltr. MPI engine</p> <p><b>Z3</b> = 2.4 ltr. MPI engine</p> <p><b>Z4</b> = 2.7 ltr. turbo MPI engine</p> <p><b>Z5</b> = 3.0 ltr. MPI engine</p> <p><b>Z6</b> = 3.2 ltr. FSI engine / 3.2 ltr. MPI engine</p> <p><b>Z7</b> = 3.7 ltr. MPI engine</p> <p><b>Z8</b> = 4.2 ltr. MPI engine / 4.2 ltr. FSI engine</p> <p><b>Z9</b> = 6.0 ltr. MPI engine</p>	
Labour:	Check the application "vehicle-specific notes" (in Service Online or ELSA) to see if the vehicle is affected by the campaign ' <b>28E9</b> ', and whether the relevant work has already been carried out.	0 TU
	Check for entry in the Service Schedule; make entry if necessary <b>after completing work required for all applicable criteria</b> :	0 TU
Audi A4 with 1.8 ltr. TMPI engine	Replace ignition coils APOS: 28 20 56 99 APOS/2: 28 E9 ** 98 (enter relevant criterion in place of **)	40 TU
Audi A3 / TT with 1.8 ltr. TMPI engine	Replace ignition coils APOS: 28 20 56 99 APOS/2: 28 E9 ** 98 (enter relevant criterion in place of **)	50 TU
Audi A3 / A4 with 1.8 ltr. TFSI engine	Replace ignition coils APOS: 28 20 56 99 APOS/2: 28 E9 ** 98 (enter relevant criterion in place of **)	40 TU
Audi A4 with 2.0 ltr. MPI engine	Replace ignition coils APOS: 28 20 56 99 APOS/2: 28 E9 ** 98 (enter relevant criterion in place of **)	40 TU
Audi A6 with 2.0 ltr. MPI engine	Replace ignition coils APOS: 28 20 56 99 APOS/2: 28 E9 ** 98 (enter relevant criterion in place of **)	40 TU
Audi A3 / A4 with 2.0 ltr. FSI engine	Replace ignition coils APOS: 28 20 56 99 APOS/2: 28 E9 ** 98 (enter relevant criterion in place of **)	40 TU

Audi TT / A3 with 2.0 ltr. TFSI engine	Replace ignition coils APOS: 28 20 56 99 APOS/2: 28 E9 ** 98 (enter relevant criterion in place of **)	40 TU
Audi A4 / A6 with 2.0 ltr. TFSI engine	Replace ignition coils APOS: 28 20 56 99 APOS/2: 28 E9 ** 98 (enter relevant criterion in place of **)	40 TU
Audi A6 with 2.4 ltr. MPI engine	Replace ignition coils APOS: 28 20 56 99 APOS/2: 28 E9 ** 98 (enter relevant criterion in place of **)	70 TU
Audi A6 with 2.7 ltr. TMPI engine	Replace ignition coils APOS: 28 20 56 99 APOS/2: 28 E9 ** 98 (enter relevant criterion in place of **)	130 TU
Audi A6 with 2.8 ltr. FSI engine	Replace ignition coils APOS: 28 20 56 99 APOS/2: 28 E9 ** 98 (enter relevant criterion in place of **)	70 TU
Audi A4 with 3.0 ltr. MPI engine	Replace ignition coils APOS: 28 20 56 99 APOS/2: 28 E9 ** 98 (enter relevant criterion in place of **)	90 TU
Audi A6 / A8 with 3.0 ltr. MPI engine	Replace ignition coils APOS: 28 20 56 99 APOS/2: 28 E9 ** 98 (enter relevant criterion in place of **)	70 TU
Audi TT with 3.2 ltr. MPI engine	Replace ignition coils APOS: 28 20 56 99 APOS/2: 28 E9 ** 98 (enter relevant criterion in place of **)	40 TU
Audi A3 with 3.2 ltr. MPI engine	Replace ignition coils APOS: 28 20 56 99 APOS/2: 28 E9 ** 98 (enter relevant criterion in place of **)	50 TU
Audi A4 / A6 with 3.2 ltr. FSI engine	Replace ignition coils APOS: 28 20 56 99 APOS/2: 28 E9 ** 98 (enter relevant criterion in place of **)	70 TU
Audi A8 with	Replace ignition coils	110 TU

3.2 ltr. FSI engine	APOS: 28 20 56 99 APOS/2: 28 E9 ** 98 (enter relevant criterion in place of **)	
Audi Q7 with 3.6 ltr. FSI engine	Replace ignition coils APOS: 28 20 56 99 APOS/2: 28 E9 ** 98 (enter relevant criterion in place of **)	50 TU
Audi A8 with 3.7 ltr. MPI engine	Replace ignition coils APOS: 28 20 56 99 APOS/2: 28 E9 ** 98 (enter relevant criterion in place of **)	90 TU
Audi A4 with 4.2 ltr. MPI engine	Replace ignition coils APOS: 28 20 56 99 APOS/2: 28 E9 ** 98 (enter relevant criterion in place of **)	110 TU
Audi A4 with 4.2 ltr. FSI engine	Replace ignition coils APOS: 28 20 56 99 APOS/2: 28 E9 ** 98 (enter relevant criterion in place of **)	70 TU
Audi A6 / A8 with 4.2 ltr. MPI engine	Replace ignition coils APOS: 28 20 56 99 APOS/2: 28 E9 ** 98 (enter relevant criterion in place of **)	90 TU
Audi A6 / A8 with 4.2 ltr. FSI engine	Replace ignition coils APOS: 28 20 56 99 APOS/2: 28 E9 ** 98 (enter relevant criterion in place of **)	90 TU
Audi Q7 with 4.2 ltr. FSI engine	Replace ignition coils APOS: 28 20 56 99 APOS/2: 28 E9 ** 98 (enter relevant criterion in place of **)	70 TU
Audi S6 / S8 / Q7 with 5.2 ltr. FSI engine	Replace ignition coils APOS: 28 20 56 99 APOS/2: 28 E9 ** 98 (enter relevant criterion in place of **)	130 TU
Audi A8 with 6.0 ltr. MPI engine	Replace ignition coils APOS: 28 20 56 99 APOS/2: 28 E9 ** 98 (enter relevant criterion in place of **)	160 TU

**Other campaigns to note:** see "vehicle-specific notes" (in Service Online or ELSA)

### Genuine parts

Engine	Quantity	Designation	Part No.
1.8 ltr. TMPI, longitudinal / transverse	4	Ignition coil	06A 905 115 D
1.8 ltr. TFSI, longitudinal / transverse	4	Ignition coil	07K 905 715 F
2.0 ltr. MPI, longitudinal / transverse	4	Ignition coil	06C 905 115 M
2.0 ltr. FSI, transverse	4	Ignition coil	07K 905 715 F
2.0 ltr. FSI, longitudinal	4	Ignition coil	06E 905 115 E
2.0 ltr. TFSI, longitudinal / transverse	4	Ignition coil	07K 905 715 F
2.4 ltr. MPI, longitudinal	6	Ignition coil	06E 905 115 E
2.7 ltr. TMPI, longitudinal	6	Ignition coil	06A 905 115 D
2.8 ltr. FSI, longitudinal	6	Ignition coil	06E 905 115 E
3.0 ltr. MPI, longitudinal	6	Ignition coil	06C 905 115 M
3.2 ltr. MPI, transverse	6	Ignition coil	022 905 715 B
3.2 ltr. FSI, longitudinal	6	Ignition coil	06C 905 115 M (AUK) 06E 905 115 E (BKH / BPK / BYU)
3.6 ltr. FSI, longitudinal	6	Ignition coil	022 905 715 A
3.7 ltr. MPI, longitudinal	8	Ignition coil	077 905 115 T
4.2 ltr. MPI, longitudinal	8	Ignition coil	06A 905 115 D (BAS) 077 905 115 T (BAT / BBK / BFM)
4.2 ltr. FSI, longitudinal	8	Ignition coil	06E 905 115 E (BAR / BVJ) 07K 905 715 F (BNS)
5.2 ltr. FSI, longitudinal	10	Ignition coil	06E 905 115 E
6.0 ltr. MPI, longitudinal	12	Ignition coil	07C 905 715 A

## Parts supply

The required genuine parts should be ordered in all cases according to requirements from your Importer (or regional distribution centre).

## Parts despatch control

GERMANY: Please note instructions for parts shipment in SAGA/2.

EXPORT COUNTRIES: After removal, parts should be returned in the normal way to the Importer's warranty inspection department.

## Repair instructions



### Technical background

It is possible that an ignition coil can fail to function, in which case the emissions warning lamp will light up, as designed. In some cases, the customer may also notice that the vehicle pulls unevenly.

### Check

If the vehicle is not already listed as repaired in the "vehicle-specific notes" (in Service Online or ELSA), check the Service Schedule for the entry '**28E9 completed**'. If the entry is not listed, carry out the required work in accordance with instructions.

### Genuine parts

Engine	Quantity	Designation	Part No.
1.8 ltr. TMPI, longitudinal / transverse	4	Ignition coil	06A 905 115 D
1.8 ltr. TFSI, longitudinal / transverse	4	Ignition coil	07K 905 715 F
2.0 ltr. MPI, longitudinal / transverse	4	Ignition coil	06C 905 115 M
2.0 ltr. FSI, transverse	4	Ignition coil	07K 905 715 F
2.0 ltr. FSI, longitudinal	4	Ignition coil	06E 905 115 E
2.0 ltr. TFSI, longitudinal / transverse	4	Ignition coil	07K 905 715 F
2.4 ltr. MPI, longitudinal	6	Ignition coil	06E 905 115 E
2.7 ltr. TMPI, longitudinal	6	Ignition coil	06A 905 115 D
2.8 ltr. FSI, longitudinal	6	Ignition coil	06E 905 115 E
3.0 ltr. MPI, longitudinal	6	Ignition coil	06C 905 115 M
3.2 ltr. MPI, transverse	6	Ignition coil	022 905 715 B

3.2 ltr. FSI, longitudinal	6	Ignition coil	06C 905 115 M (AUK) 06E 905 115 E (BKH / BPK / BYU)
3.6 ltr. FSI, longitudinal	6	Ignition coil	022 905 715 A
3.7 ltr. MPI, longitudinal	8	Ignition coil	077 905 115 T
4.2 ltr. MPI, longitudinal	8	Ignition coil	06A 905 115 D (BAS) 077 905 115 T (BAT / BBK / BFM)
4.2 ltr. FSI, longitudinal	8	Ignition coil	06E 905 115 E (BAR / BVJ) 07K 905 715 F (BNS)
5.2 ltr. FSI, longitudinal	10	Ignition coil	06E 905 115 E
6.0 ltr. MPI, longitudinal	12	Ignition coil	07C 905 715 A

## Tools

### Special tools, test equipment and auxiliary items required

- Puller -T40039-

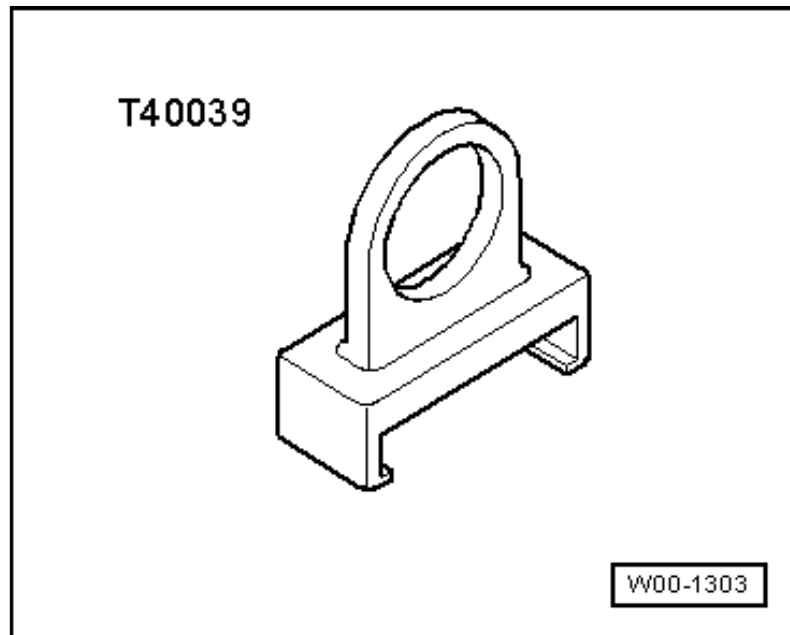

- Assembly tool -T10118-  
(only for 3.2 ltr. MPI  
transverse engine)

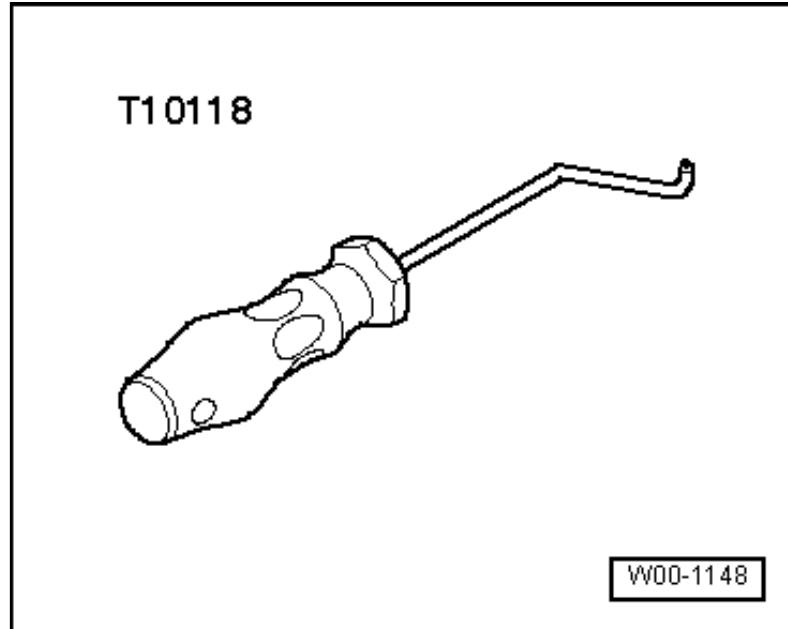

- Puller -T10095/a-

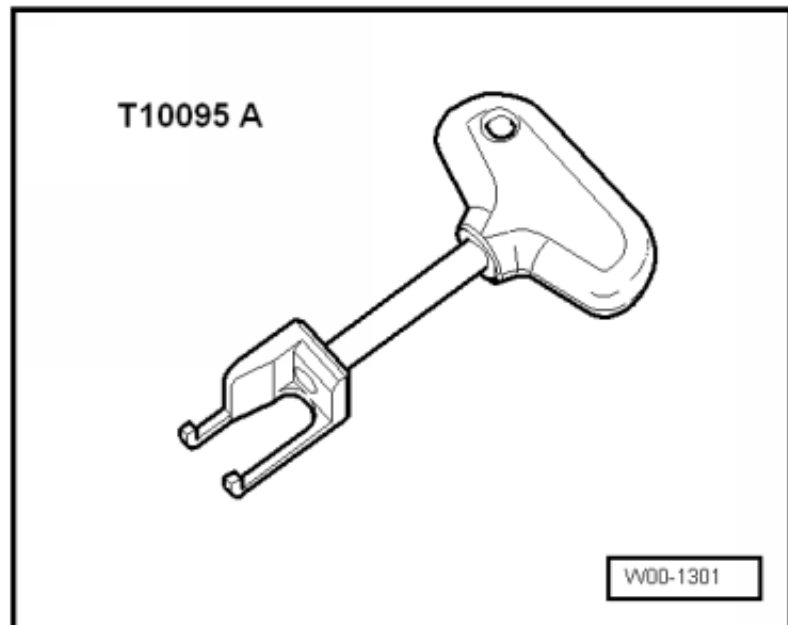

## Work

### Checking and replacing ignition coils

- Remove ignition coils.

=> Workshop Manual, Injection and ignition system; Rep. Gr. 28; Servicing ignition system; [“Removing and installing ignition coils”](#)

- Check the part number of each



ignition coil:

- If the part number of any of the ignition coils is not as listed below, replace that ignition coil.
- If the part number of the ignition coil is the same as one of the numbers in the list, the coil does not have to be replaced.



**List of ignition coils**

Engine	Engine code	A. Ignition coils with these Part Nos. can remain in the vehicle; no replacement necessary:	B. If the part numbers of ignition coils fitted in the vehicle are not as listed in column A, replace with the following:
1.8 ltr. TMPI	AGU AMB AKM ARX ARY AUM AUQ AVJ AWM AWT	06A 905 115 D 06B 905 115 R 06C 905 115 L 06C 905 115 M	06A 905 115 D

	BAM BEX BFB BFV BVP BVR		
1.8 ltr. TFSI	BUL BYT	07K 905 715 F 07K 905 715 D	07K 905 715 F
2.0 ltr. MPI	ALT	06C 905 115 M 06C 905 115 L	06C 905 115 M
2.0 ltr. FSI, longitudinal	AWA	06E 905 115 E 06E 905 115 D 06D 905 115 K	06E 905 115 E
2.0 ltr. FSI, transverse	AXW BLR BLX BLY BMB BVY BVZ	07K 905 715 F 07K 905 715 D 06F 905 115 F	07K 905 715 F
2.0 ltr. TFSI	AXX BGB BHZ BPG BPJ BWA BWE BWT BYK	07K 905 715 F 07K 905 715 D 06H 905 115 06F 905 115 F	07K 905 715 F
2.4 ltr. MPI	BDW	06E 905 115 E 06E 905 115 D	06E 905 115 E
2.7 ltr. TMPI		06A 905 115 D	

	BEL BES	06B 905 115 R 06C 905 115 M 06C 905 115 L	06A 905 115 D
2.8 ltr. FSI	BDX	06E 905 115 E 06E 905 115 D 06D 905 115 K	06E 905 115 E
3.0 ltr. FSI	ASN AVK BBJ	06C 905 115 M 06C 905 115 L 06B 905 115 R 06A 905 115 D	06C 905 115 M
3.2 ltr. FSI	BDB BHE BMJ BUB	022 905 715 B 022 905 715	022 905 715 B
	AUK	06C 905 115 M 06C 905 115 L 06B 905 115 R 06A 905 115 D	06C 905 115 M
	BKH BPK BYU	06E 905 115 E 06E 905 115 D 06D 905 115 K	06E 905 115 E
3.6 ltr. FSI	BHK	022 905 715 A 022 905 715 B	022 905 715 A
3.7 ltr. MPI	BFL	077 905 115 T 077 905 115 S 077 905 115 Q	077 905 115 T
4.2 ltr. MPI	BAS	06B 905 115 R 06A 905 115 D	06A 905 115 D
	BAT BBK BFM	077 905 115 T 077 905 115 S 077 905 115 Q	077 905 115 T

4.2 ltr. FSI	BAR	06E 905 115 E	06E 905 115 E
	BVJ	06E 905 115 D 06D 905 115 K	
5.2 ltr. FSI	BNS	07K 905 715 F 07K 905 715 D 06F 905 115 F	07K 905 715 F
	BGS BSM BXA	06E 905 115 E 06E 905 115 D 06D 905 115 K	06E 905 115 E
6.0 ltr. MPI	AZC BHT BTE	07C 905 715 A 07C 905 115 J	07C 905 715 A

### Identification

After completion of **all** required work, make the entry "28E9 completed" (including date and workshop stamp) in the first vacant box in the Service Record section of the Service Schedule or in the section for Workshop remarks.

 **Repair instructions**  **Notes**