

Toothed belt - exploded view of components

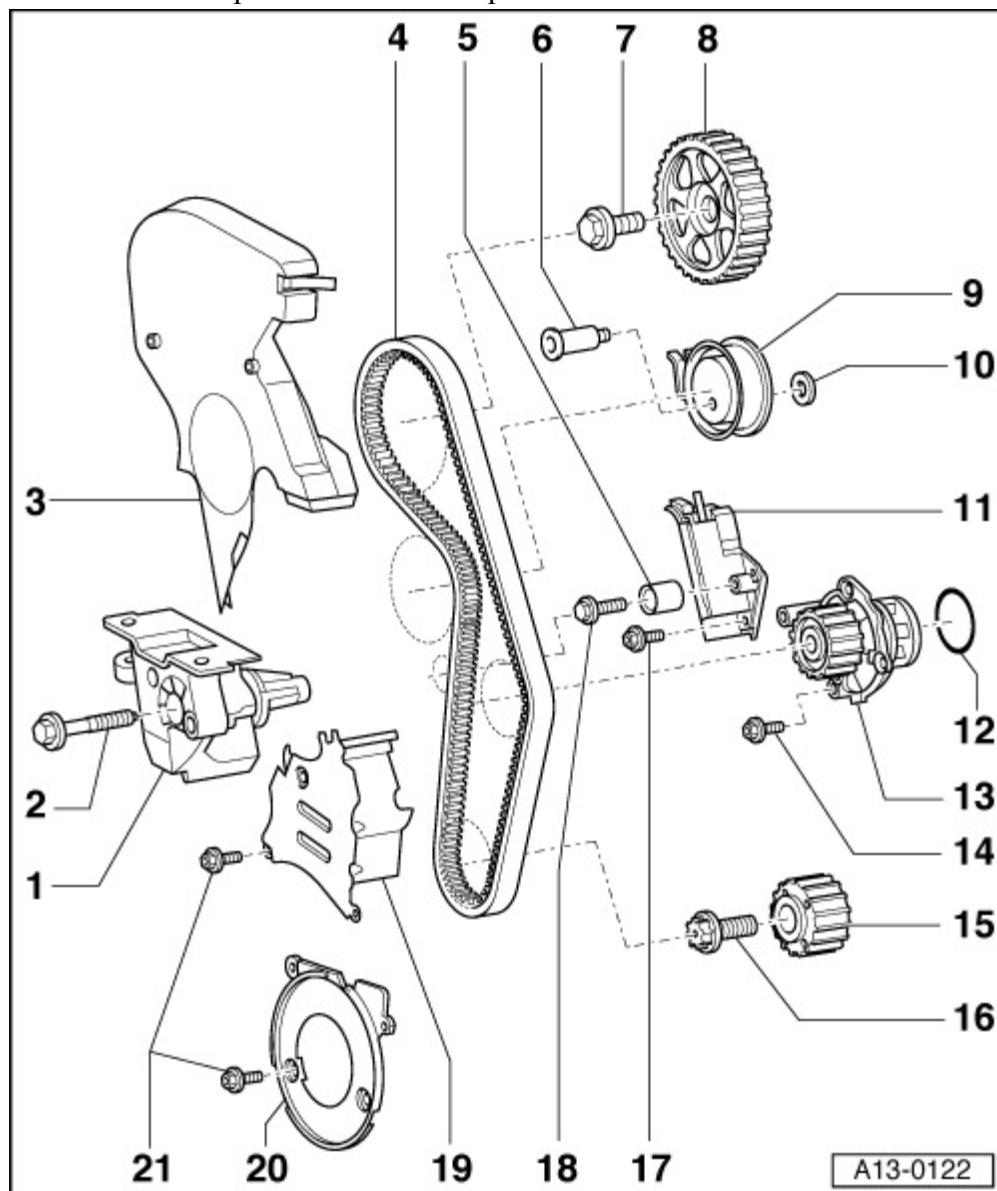

1 - Engine support

2 - 45 Nm

3 - Toothed belt cover (top)

q To remove toothed belt cover, it may be necessary to unbolt bracket for coolant return line (for turbocharger).

q Engage carefully in centre toothed belt cover when installing

4 - Toothed belt

q Before removing, mark direction of rotation with chalk or felt-tipped pen. If the belt runs in the opposite direction when it is refitted, this can cause breakage

q Check for wear

q Removing → [Chapter](#)

q Installing (adjusting valve timing) → [Anchor](#)

5 - Idler roller

6 - 27 Nm

7 - 65 Nm

q Use counterhold tool -3036- when loosening and tightening → [Fig.](#)

8 - Camshaft sprocket for exhaust camshaft

q Remove toothed belt prior to removing and installing → [Chapter](#)

q Installation position → [Fig.](#)

9 - Tensioning roller

10 - Washer

11 - Tensioner for toothed belt

12 - O-ring

q Renew

q Lubricate with coolant additive Plus -G 012 A8F A1- prior to installing

13 - Coolant pump

q Removing and installing → [Chapter](#)

14 - 15 Nm

15 - Crankshaft sprocket

q Contact surface between sprocket and crankshaft must be free of oil

q Can only be installed in one position

16 - 90 Nm + 90° ($\frac{1}{4}$ turn) further

q Renew

q Do not lubricate with oil

q Use counterhold tool -3415- when loosening and tightening → [Fig.](#)

17 - 15 Nm

18 - 25 Nm

19 - Toothed belt cover (centre)

20 - Toothed belt cover (bottom)

21 - 10 Nm

q Install using locking fluid; for locking fluid refer to → [Parts catalogue](#)

Loosening and tightening bolt for
camshaft sprocket

– Use counterhold tool -3036- when
loosening and tightening central bolt.

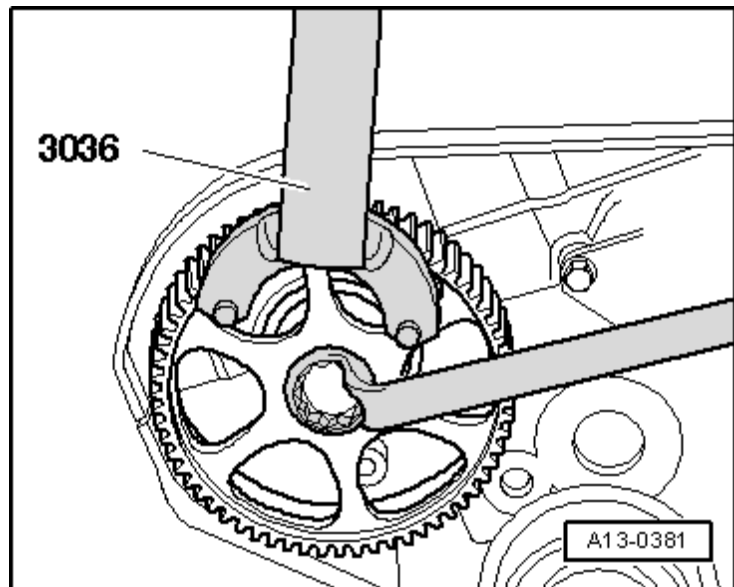

Installation position of camshaft sprocket

The thinner web of the camshaft sprocket faces outwards -arrows- and the marking "OT" for TDC is visible from the front.

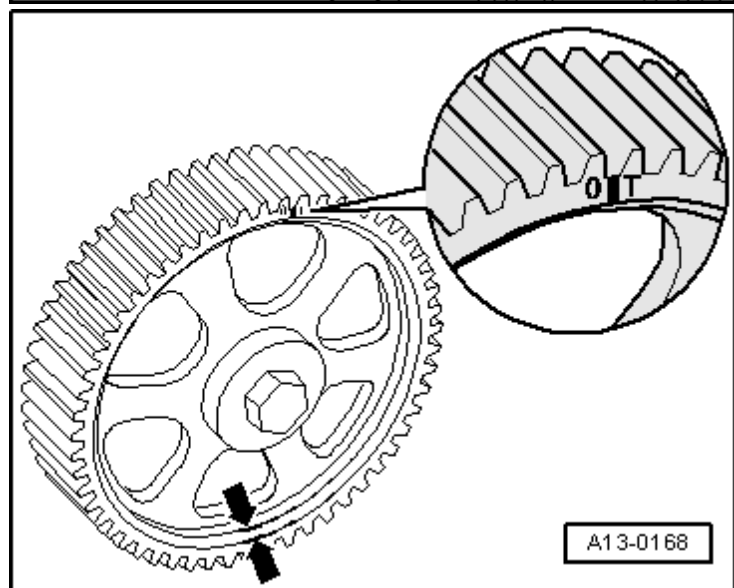

Removing and installing crankshaft sprocket

– Use counterhold tool -3415- when loosening and tightening central bolt.

